



RODGERS
PAPER MILL



	Index	i, ii
<hr/>		
1 Introduction	Mission Statement	1.1
	Core Values	1.1
	Brand Position Statement	1.1
<hr/>		
2 Logo	Mark Description	2.1
	Primary, Secondary	2.2
	Mark/ Accepted Colors	2.3
	Clear Space & Sizing	2.4
<hr/>		
3 Color	Color Palette	3.1, 3.2
<hr/>		
4 Publications	Typography	4.1, 4.2
	Grid & Layout	4.3
	Posters	4.4
	Cover Design	4.5
	Press Kits	4.6
<hr/>		
5 Stationery	Letterhead & Business Cards	5.1
<hr/>		
6 Photography/Illustrations	Photography Style	6.1
	Illustration Style	6.2
<hr/>		
7 Way Finding	Facility Map	7.1
	Icon System	7.2



8 Parking	Parking Area	8.1
	Entrance Monument	8.2

9 Uniforms & Merch	Uniform Patch	9.1
	Merch Shop	9.2
	PPE Branding	9.3

10 Recognition Program	Trophy Design	10.1
-------------------------------	---------------------	------

11 Vehicles	Fleet Trucks	11.1
	Heavy Equipment	11.2
	Pick-up Trucks/Vans	11.3
	In-motion Visibility	11.4

12 Murals	History of Paper Mural	12.1
	Other Murals	12.2

13 Website	Sitemap & Wireframe	13.1
	Homepage	13.2
	Interior Page Design	13.3
	Contact Page	13.4



SECTION 1

INTRODUCTION



Mission Statement

Rodgers Paper Mill exists to produce reliable, precision made paper while honoring the people, processes, and resources that make the work possible. Through stewardship, clarity, and respect for labor, we support the industries and communities that depend on materials done right.

Core Values

- 1. Craft with Purpose-** We believe materials should be made with intention, precision, and respect for process. Every sheet reflects the care of the people and systems behind it.
- 2. Stewardship of Resources-** We're responsible for the materials, the land we operate on, and the impact we leave behind—today and for future generations.
- 3. Respect for Labor-** We value the skill, safety, and experience of the people who keep the mill running.
- 4. Clarity Over Complexity-** Clear systems create safer, more efficient workplaces. We prioritize legibility, organization, and direct communication.
- 5. Built to Last-** We design systems, products, and relationships meant to endure.

Brand Positioning Statement

Rodgers Paper Mill is a modern paper manufacturer serving industrial and commercial partners with precision-made paper, grounded in generational labor, stewardship, and operational excellence.



SECTION 2
LOGO



Logo Description The **Rodgers Paper Mill** logo is a symbolic fusion of material craft and mechanical precision, reflecting the brand’s foundation in Southern labor traditions and modern manufacturing discipline. The logo balances heritage and function. The geometry is sturdy and utilitarian, inspired by factory tools and industrial typography.

The simplified forms ensure clarity, scalability, and legibility across applications—packaging, uniforms, signage and digital use.

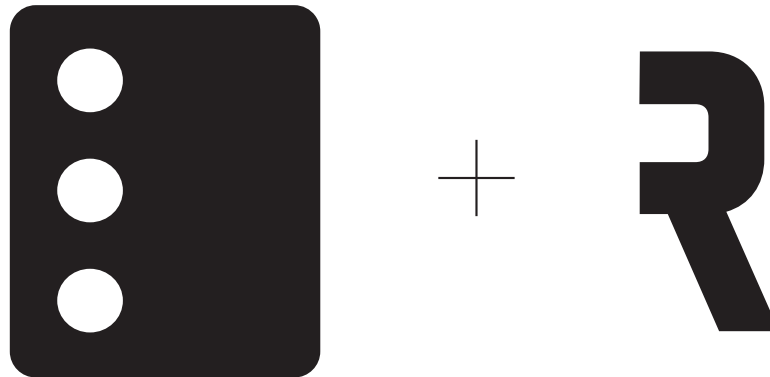

Classic Perforated Paper

Standard Open Wrench

Breakdown

Classic Perforated Paper- represented by the vertical series of circular cutouts, referencing continuous-feed industrial paper, utility forms, and the legacy of paper production.

Standard Open Wrench- abstracted into the negative space of the letterform, symbolizing labor, maintenance, and the hands-on work required to keep industry moving.

These elements are unified into a single, bold “R” monogram, reinforcing the Rodgers name while visually expressing the relationship between material and machine. The rounded rectangle container evokes industrial labeling, mill signage and equipment badges.



Primary Logo

The **primary Rodgers Paper Mill logo** is the stacked configuration featuring the R monogram positioned above the full wordmark and descriptor. This version functions as the brand's formal seal and should be used for first impressions, institutional materials, and primary brand expressions. It establishes authority, and reinforces the industrial heritage of the company.



Secondary Logo

The **secondary logo** uses a horizontal arrangement of the “R” monogram and wordmark for applications where **vertical space is limited**. This version maintains full brand identification while offering flexibility across layouts: signage, documents, and digital headers.



2 LOGO



Mark/ Accepted Colors

The mark consists solely of the R monogram and is used when space is restricted or when brand recognition has already been established. It is intended for utility-driven applications such as labels, equipment markings, stamps, and digital interfaces.



Signature

Borderless

Rounded



Clear Space

To maintain clarity and visual integrity, the Rodgers Paper Mill logo must be surrounded by a minimum amount of clear space. No typography, imagery, or graphic elements may enter this area.

Clear Space Definition

Clear space is defined using the diameter of **one perforation circle** within the R monogram. The minimum clear space on all sides of the logo is:

1× circle perforation diameter.

This measurement applies to the primary, secondary, and icon versions of the logo.

Clear space is measured from the outermost edge of the logo container or letterforms. This proportional system ensures consistent legibility across all sizes and applications.

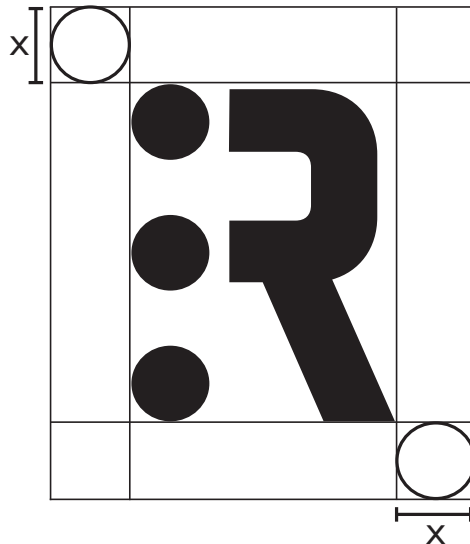

x = diameter of perforation circle
Minimum clear space = 1x



Minimum Size

To ensure legibility and reproduction quality, the logo should never be displayed smaller than the sizes listed below.

Primary Logo (Stacked)

Print: Minimum height of 1.25 inches

Digital: Minimum height of 120 px

Secondary Logo (Horizontal)

Print: Minimum width of 1.75 inches

Digital: Minimum width of 160 px

Icon

Print: Minimum width of 0.5 inches

Digital: Minimum width of 32 px

Use of the logo below these sizes may compromise clarity and should be avoided.

Unacceptable

The logo should never be: crowded by text or imagery, placed within the clear space of another brand, reduced below minimum size, altered, redrawn, or re-proportioned.

Unacceptable Examples:



Re-proportioned



Over Crowded



Altered



SECTION 3
COLOR



Primary Color



Mill Navy serves as the foundation of the Rodgers Paper Mill visual identity. The deep blue references industrial machinery, ink-dense paper stock, and the institutional environments in which paper products are produced and used. Its muted tone conveys reliability, precision, and restraint, establishing a serious brand presence.

Mill Navy should be used as the dominant background color and primary brand identifier across signage, packaging, digital interfaces, and corporate materials.

Mill Navy

HEX #131E32
RGB 19, 30, 50
HSB 219, 62%, 20%
CMYK 92, 82, 53, 60

Secondary Color



Machine Gold functions as a supporting accent color, providing contrast and emphasis within the brand system. Inspired by safety markings, industrial coatings, and utilitarian equipment finishes, this color introduces visibility without overpowering the core identity.

Machine Gold should be used intentionally and sparingly to highlight key elements such as the logo mark, navigational details, calls to action, or informational accents.

Machine Gold

HEX #FBB040
RGB 251, 176, 64
HSB 36, 75%, 98%
CMYK 0, 35, 85, 0



Utility Color 1

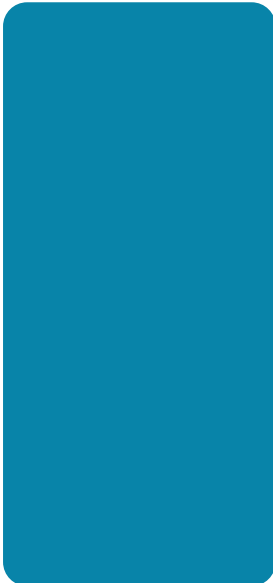

Process Blue introduces clarity and structure within diagrams, facility maps, and technical communications. Inspired by drafting inks and industrial blueprint markings, this color supports information hierarchy without competing with Mill Navy as the dominant brand tone.

Process Blue should be used sparingly and primarily within structured or instructional contexts.

Process Blue

HEX #0083A9
RGB 0, 131, 169
HSB 193, 100%, 66%
CMYK 85, 28, 16, 11

Utility Color 2



Signal Red functions as a high-visibility accent derived from industrial safety markings and machinery indicators. It is used to draw attention to critical information, warnings, or emphasized elements within controlled applications.

Signal Red should never replace **Mill Navy** as a dominant color and should be applied with restraint.

Signal Red

HEX #AB1C1E
RGB 171, 28, 30
HSB 359, 84%, 67%
CMYK 15, 100, 90, 10



SECTION 4
PUBLICATIONS



Typeface Overview

The **Rodgers Paper Mill** typography system balances industrial strength, clarity, and readability. Typeface selection reflects the brand's foundation in manufacturing while ensuring consistency across print and digital applications. Display and supporting typefaces establish character and hierarchy, while a neutral body type supports long-form readability.

Primary Display Typeface

INDUSTRY INC.

Industry Inc. is the primary display typeface of **Rodgers Paper Mill** and is used for logotypes, primary headlines, and high-impact brand applications. Its bold, mechanical forms reference industrial labeling, machinery markings, and factory signage.

This typeface should be used sparingly and intentionally, serving as a visual anchor rather than a body text solution.

Primary Uses:

- Logotype
- Primary headlines
- Large-scale signage
- Brand statements

Secondary Typeface

Brandon Grotesque

Brandon Grotesque serves as the secondary typeface and is used for descriptors, subheadings, and supporting brand language. Its geometric structure complements the industrial nature of the primary display type while introducing clarity and refinement.

This typeface helps bridge the gap between bold industrial expression and functional communication.

Primary Uses:

- Descriptors
- Subheadings
- Short-form copy
- Navigational elements



Body Typeface

Nunito Sans

Nunito Sans is the primary body text typeface for Rodgers Paper Mill. Its clean, humanist forms ensure legibility across long-form text, digital interfaces, and technical documentation.

The rounded characteristics soften the overall system without compromising professionalism, supporting extended reading while maintaining consistency with the brand's utilitarian tone.

Primary Uses:

- Body copy
- Captions
- Long-form text
- Digital UI content

Typography Hierarchy

Level 1 — Primary Headline

Typeface: Industry Inc., size 20pt

Usage: High-impact headlines, section openers, and primary brand statements.

Level 2 — Secondary Headline

Typeface: Brandon Grotesque, size 16pt

Usage: Subheadings and supporting headlines that introduce content sections and reinforce hierarchy.

Level 3 — Descriptor / Label

Typeface: Brandon Grotesque, size 14pt

Usage: Descriptors, labels, captions, and navigational elements.

Level 4 — Body Copy

Typeface: Nunito Sans, size 11pt

Usage: Used for paragraphs, long-form content, and informational text. Optimized for readability at smaller sizes.

Level 5 — Caption / Meta Text

Typeface: Nunito Sans, size 9pt

Usage: Used for captions, footnotes, legends, and secondary informational content.



Grid & Layout

Grid Overview

Rodgers Paper Mill layouts are built on a structured grid system to ensure consistency, clarity, and visual order across all applications. The grid reflects the brand's industrial foundation and supports clear hierarchy across logo, typography, and content.

US Letter (8.5inx11in)

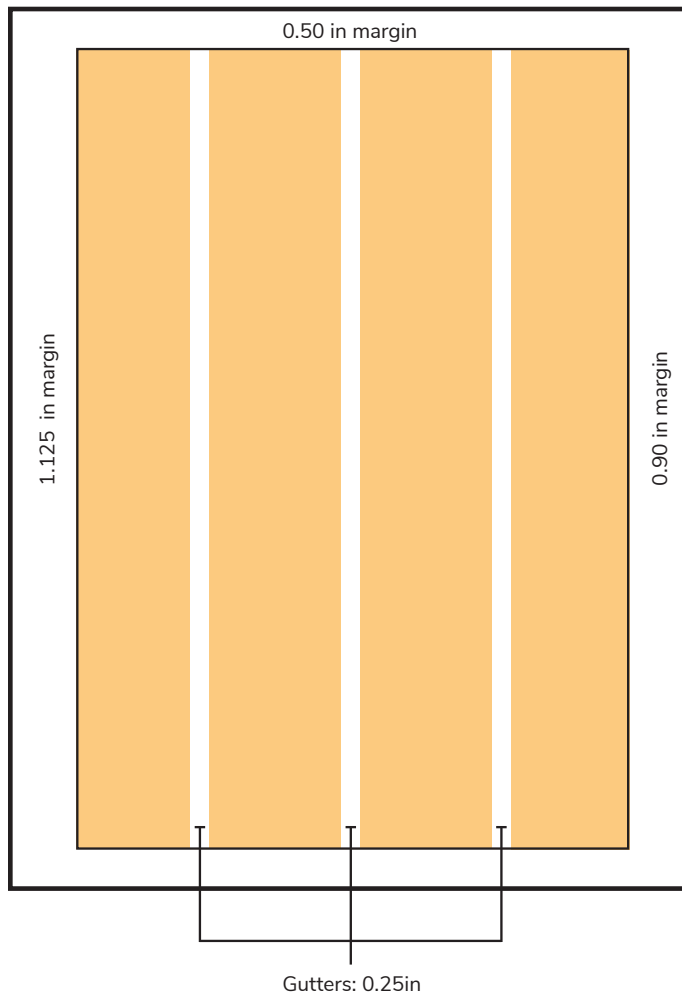

Base Grid Structure

Column System: 4-column grid

Alignment: All elements align to the column grid or margin edges.

This flexible grid accommodates both vertical and horizontal layouts while maintaining consistent structure.

Layout Rules

- Logos align to the grid, never floating arbitrarily
- Headlines align to column edges
- Body copy flows within single or multiple columns
- Spacing between elements follows consistent increments
- Elements should not break the grid unless intentionally emphasized

Margins

- 0.50 in on top and bottom
- 1.125 in on left
- 0.90 in on right



SECTION 5
STATIONERY



Letterhead & Business Card

US Letter (8.5inx11in)

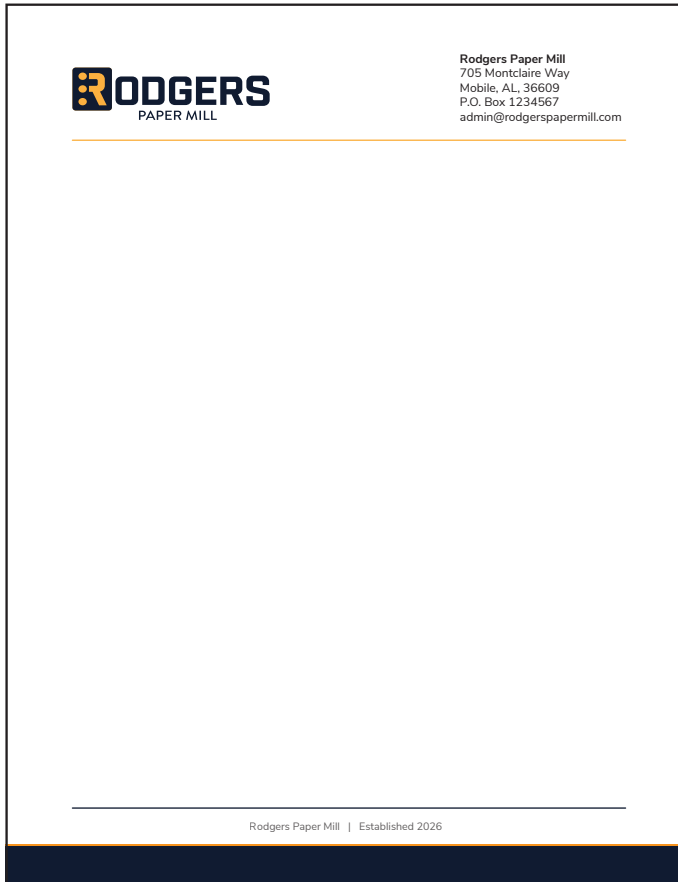

The **Rodgers Paper Mill** stationery system emphasizes clarity, restraint, and material authenticity. The layout is intentionally minimal, allowing the brand mark and typography to stand confidently within a structured grid while generous white space reflects the importance of paper as the company's primary product. This approach ensures the stationery feels practical, refined, and consistent with the identity of a historic paper manufacturer. The navy and gold palette reinforces the brand's industrial heritage while maintaining a modern appearance.

Business Card Front and Back (3.5inx2in)

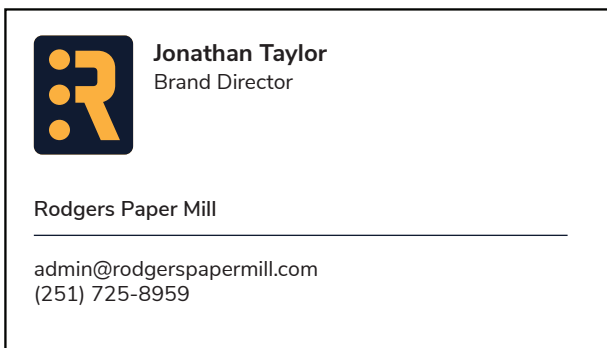



SECTION 6

PHOTOGRAPHY/ ILLUSTRATIONS



Photography

Rodgers Paper Mill photography emphasizes process, material, and labor. Imagery should feel documentary in nature, capturing environments and subjects as they exist rather than staged or overly stylized scenes. Photography supports the brand's industrial foundation and reinforces authenticity, precision, and reliability.



Subject Matter

- Paper in raw or unfinished states
- Industrial machinery and tools
- Factory environments and work surfaces
- Process details (cuts, edges, stacks, textures)
- Human presence through hands or partial figures
- Photography should focus on work being done, not posing



Composition & Framing

- Images should feel grounded and intentional
- Subjects are centered or aligned to strong verticals and horizontals
- Cropping may be tight to emphasize texture and scale
- Wide negative space is encouraged when appropriate
- Avoid dynamic angles or exaggerated perspective.



Lighting & Color Treatment

- Natural or ambient industrial lighting is preferred
- Shadows are acceptable and encouraged
- Color treatment should remain neutral and slightly muted
- Avoid high saturation, heavy filters, or dramatic color grading
- Photography should reflect real working environments.

Images shown are reference examples used to illustrate visual direction and were not created by Rodgers Paper Mill

Usage Guidelines

- Photography should support typography, not compete with it
- Images may be used full-bleed or contained within the grid
- Overlays and effects should be minimal or avoided



Illustration

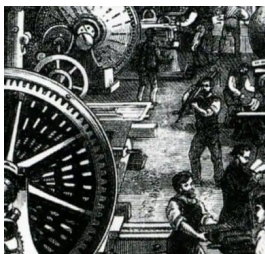
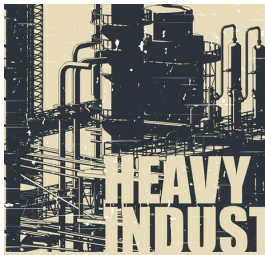
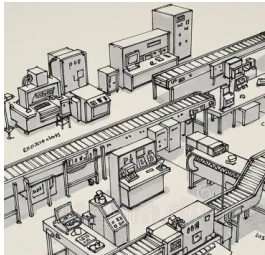

Images shown are reference examples used to illustrate visual direction and were not created by Rodgers Paper Mill

Rodgers Paper Mill illustrations are used to communicate process, systems, and structure. Illustration style is technical and referential, drawing from industrial diagrams, archival factory engravings, and instructional schematics. Illustrations should prioritize clarity and function over expression.

Illustration Types

- Technical diagrams and schematics
- Process maps and system layouts
- Archival-style industrial illustrations
- Simplified factory or machinery renderings
- Illustrations should communicate how things work, move, or connect.

Line & Form

- Line work is clean, controlled, and intentional
- Line weight remains consistent within a composition
- Forms are simplified and geometric
- Perspective is orthographic or isometric when possible
- Avoid expressive, hand-drawn, or sketch-like styles
- Illustrations should feel engineered rather than illustrative.

Color & Texture Treatment

- Primary use of monochrome or limited color
- Line illustrations may appear in black, white, or Mill Navy
- Accent color (Machine Gold) may be used sparingly for emphasis
- Texture should reference print artifacts (grain, distress) only when appropriate
- Avoid gradients, shading effects, or decorative textures.

Usage Guidelines

- Illustrations should support information, not decoration
- Align illustrations to the grid system
- Use illustrations to explain process, layout, or scale
- Avoid mixing illustration styles within a single application



SECTION 7

WAYFINDING



Facility Map

The **Rodgers Paper Mill** facility map was developed using a drone photograph of the Rodgers Paper Mill as a reference to accurately capture the layout of the site. The aerial image was simplified and redrawn into an isometric diagram, reducing the buildings into clear geometric forms that represent the key structures of the facility. This diagram then served as the basis for a fabricated metal directory sign, where each building is translated into individual metal elements mounted to a panel, creating a durable and dimensional wayfinding piece that reflects the industrial character of the mill. Other uses include employee wayfinding, visitor orientation, safety reference, and educational displays explaining the mill's processes.

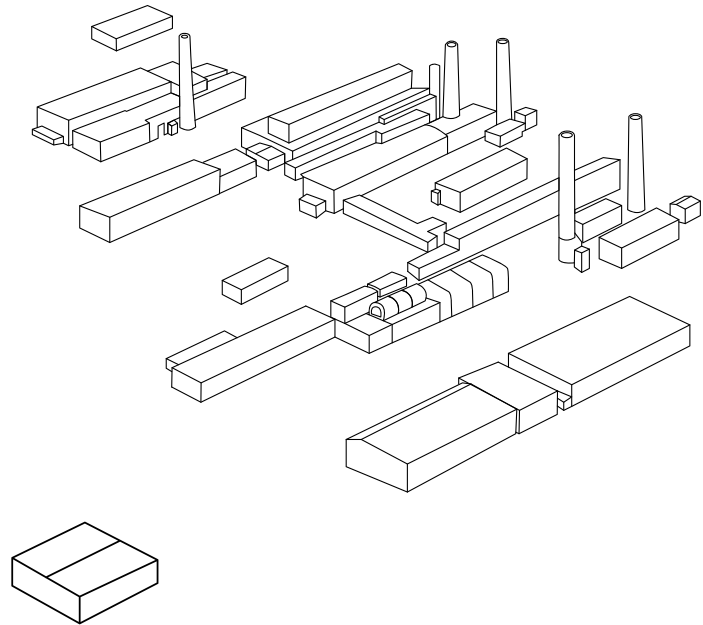

Illustration from drone photograph



Drone photograph of Rodgers Paper Mill



Illustration translated into a dimensional metal directory sign



Icon System

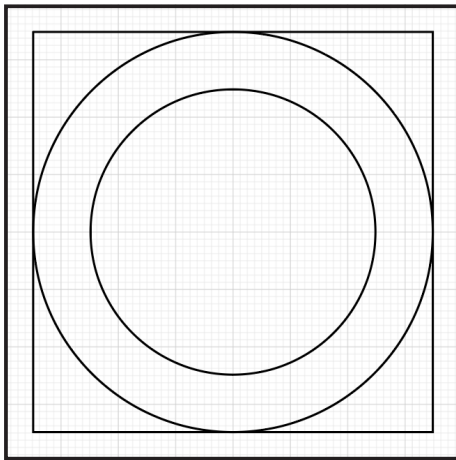

The **Rodgers Paper Mill** icon system was designed to establish a clear and consistent visual language across the mill's campus. Built on a geometric keyline grid, each icon uses simplified forms and uniform line weights to support legibility, consistency, and ease of recognition. The system can be applied to wayfinding, safety communication, facility identification, and internal operations materials.

Keyline Grid

Page Size: 64px

Grid: 8x8

Inner circle: 40px

Outer circle/square: 56px

Stroke Weight: 3pt

Example Icons:

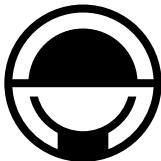

HARD HAT
AREA

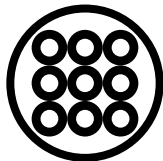

LUMBER
STORAGE

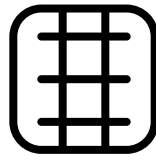

SCAFFOLDING
AREA



HOT WATER
LINE



CART TRAFFIC
ONLY



PACKAGING
ZONE



TWO PERSON
OPERATION

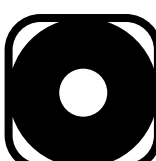

CONFINED SPACE
ENTRY



AUTHORIZED
PERSONNEL
ONLY



BADGE
REQUIRED



SECTION 8
PARKING

8 PARKING



Parking Area

The parking system translates **Rodgers Paper Mill's** identity into a functional environment. Regulatory markings maintain accessibility standards. Branded signage reinforces hierarchy and clarity, creating a cohesive system that extends the brand into everyday use.

Reserved Parking Sign
with changeable nameplate

Branded Tire Stop
with logo front and back

Painted Ground Logo
white for ADA compliance



Reserved Parking Sign



Branded Tire Stop



Entrance Monument

Designed to make a powerful first impression, this entrance monument transforms a company name into a landmark. The oversized sculptural “R” rises nearly 12 feet, creating a bold, recognizable form that communicates strength, legacy, and permanence. Set on a solid stone base with dimensional lettering, the structure feels rooted, industrial, and built to last.

Size: 10ft-12ft

Monument material: Sheet metal

Base Material: Stone

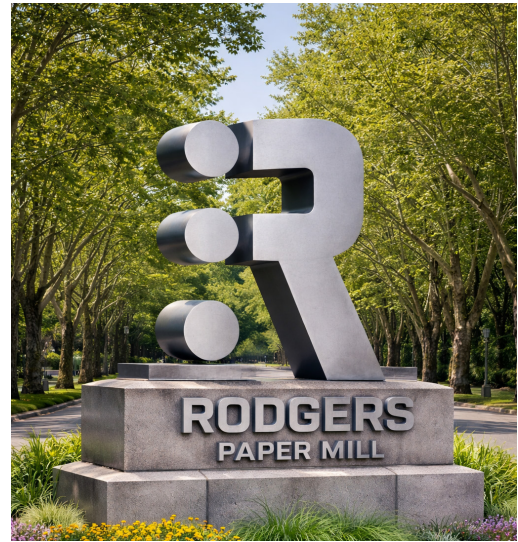



SECTION 9

**UNIFORMS
& MERCH**



Uniform Shirt

The **Rodgers Paper Mill** Uniform showcases a name patch that integrates the three brand dots seen in the mark. The patch also showcases the the brand's utility colors. The name patch is located above the left pocket. Over the right pocket is the embroidered business logo: "**Rodgers Paper Mill**". The shirt is dark navy with dark red buttons.



Patch design



Patch mock up

